

Marine Gasoline Series

120R-RAC-01 and 120R-RAC-02

Fuel Filter/Water Separators

Instruction Part Number 10223 Rev C



120R-RAC series filter assemblies were designed specifically for marine gasoline applications. These high-performance filters will help your engine run better than ever with clean, water-free fuel. The legendary Aquabloc® media removes 99% of free water and sediment down to 10 micron (nominal). With four port mounting versatility and simple servicing procedures, there has never been a better choice for your marine application than a Racor fuel filter/water separator.

Model number 120R-RAC-02 is marine UL Listed and USCG approved.

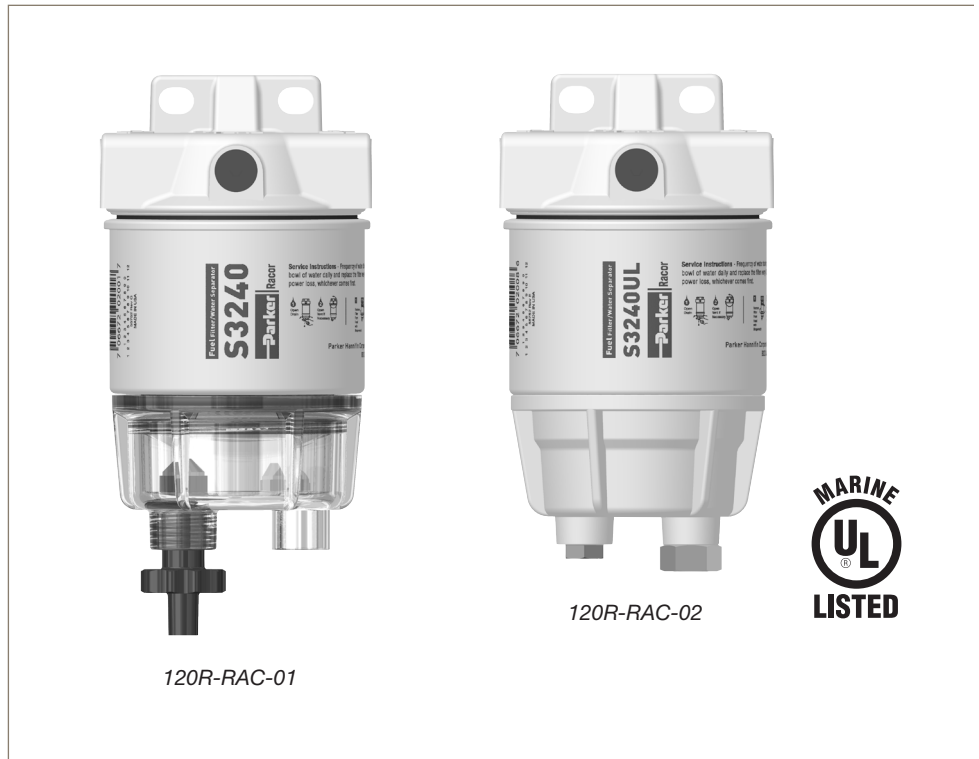

Contact Information

Parker Hannifin Corporation
Racor Division
 P.O. Box 3208
 3400 Finch Road
 Modesto, CA 95353

phone 800 344 3286
 209 521 7860
 fax 209 529 3278
 racor@parker.com

parker.com/racor



Specifications	120R-RAC-01	120R-RAC-02
Application: Inboard Outboard	No Yes	Yes Yes
Maximum Flow Rate	30 GPH (114 LPH)	30 GPH (114 LPH)
Replacement Filter	S3240	S3240TUL
Center Threads	M18 x 1.5	M18 x 1.5
Port Size	1/4"-18 NPTF	1/4"-18 NPTF
Number of Ports: Inlets Outlets	2 2	2 2
Height	6.5 in. (16.5 cm)	6.0 in. (15.2 cm)
Width	3.2 in. (8.1 cm)	3.2 in. (8.1 cm)
Depth	3.2 in. (8.1 cm)	3.2 in. (8.1 cm)
Weight (dry)	1.1 lb (0.5 kg)	1.2 lb (0.6 kg)
Clean Pressure Drop	0.15 PSI (0.01 bar)	0.15 PSI (0.01 bar)
Maximum Allowable Pressure	7 PSI (0.5 bar)	7 PSI (0.5 bar)
Underbowl Clearance	2.0 in. (5.1 cm)	2.0 in. (5.1 cm)
Water Removal Efficiency	99%	99%
Ambient Temperature Range	-40° to +255°F (-40° to +124°C)	
Maximum Fuel Temperature	190°F (88°C)	

Installation Guidelines

Danger! Great care must be exercised to avoid potential fire hazards during installations. Do not smoke or permit open flames or sparks near the fuel system.

Refer to Installation Diagram on page 4 prior to beginning installation.

- Any secondary or pressure side filters located between pump and engine should be serviced and left in place.
- Mount unit vertically on suction side of fuel pump, transfer pump, or non-removable filters, whichever comes first.
- Maintain 2" (5.1 cm) vertical clearance below filter for servicing bowl and replacing filter.
- Ensure a suitable pipe thread sealing compound is used on NPT threads of fitting prior to installation into head. For mounting flexibility, there are two inlet ports and two outlet port. Plated steel fittings are recommended. Plug unused ports with provided steel NPT plugs—do not use tapes on NPT threads.
- Use quality fuel hose in maximum fuel line size applicable to reduce potential fuel flow restrictions. Note: USCG accepted hose recommended.
- Thread fittings into appropriate fuel ports and tighten snugly. Plug unused ports (if any) with port plugs and tighten snugly.
- Attach fuel lines to filter. Avoid tight bends, rubbing areas and heat sources when routing hose.
- Follow Priming Instructions.

Priming

Always follow your engine manufacturer's guidelines for priming the fuel system. To prime the filter:

1. Spin bowl and filter off of mounting head (together).
2. Fill filter with clean fuel.
3. Apply a coat of motor oil or clean fuel to filter gasket.
4. Spin bowl and filter (together) onto mounting head tighten by hand—do not use tools.
5. Start engine and check for leaks. Correct as necessary with engine off.

Service

Draining The Bowl

Water is heavier than fuel and will settle to bottom of bowl and appear different in color. In high humidity environments, check bowl frequently (daily if a poor fuel source is suspected).

1. Make sure engine is off and cool to touch.
2. Close shut-off valve between fuel tank and filter, if applicable.
3. Open vent plug on mounting head.
4. Slowly open drain on bottom of collection bowl and allow only water to drain out—do not leave drain open for very long as it will eventually drain the entire filter of all water and fuel.
5. When fuel is detected coming out of drain, close drain quickly and tighten snugly.
6. Close vent plug and tighten snugly.
7. Open Shut-off valve if applicable.
8. Follow Priming instructions.

Filter Replacement

Filter replacement frequency is determined by contamination level in fuels. Fuel flow to engine becomes restricted as filter gradually plugs with contaminants, resulting in noticeable power loss and/or hard starting. As a guideline, change filter every 500 hours, every other oil change, annually, or at first indication of power loss, whichever occurs first. Always carry extra replacement filters as one tankful of excessively dirty fuel can quickly plug a filter.

1. Clean all debris or dirt away from head of filter assembly prior to servicing.
2. Place a container of sufficient volume below filter assembly to collect contaminants.
3. Close tank outlet valve if tank is mounted higher than filter, if equipped.
4. Open drain (remove plug on -02 model) to empty filter assembly of fuel.
5. Spin filter and bowl off together, then remove bowl from filter.
6. Dispose of filter properly.
7. Clean bowl O-ring gland and sealing surface of mounting head free of dirt, debris, or gums.
8. Apply motor oil to new filter seal and bowl O-ring (supplied with new filter).
9. Place filter seal onto filter and O-ring into bowl gland.
10. Spin bowl onto new filter snugly by hand—do not use tools.
11. Priming fuel system following your manufacturer's procedures, if necessary; otherwise, see Priming section.

Replacement Parts

Part Number	Description
1. RK 10214-01	Head Kit
2. 10224	3/8"-24 UNF Vent Plug
3. RK 10503	Gasket Kit
4. S3240	120R-RAC-01: 10 micron Replacement Filter (includes #'s 3 and 5)
S3240UL	120R-RAC-02: 10 micron Replacement Filter (includes #'s 3 and 5)
5. RK 10012	Bowl O-ring Kit
6. RK 10222	Clear Bowl Kit (-01 model) (includes #'s 5 and 7)
7. RK 30476	Self-venting Drain Kit
8. RK10553	Metal Bowl Kit (-02 model) (includes #'s 5, 9, and 10)
9. RK 20022	Probe Plug Kit (1/2"-20 UNF)
10. 01SP-2S	Drain Plug Kit (1/8" NPTF)

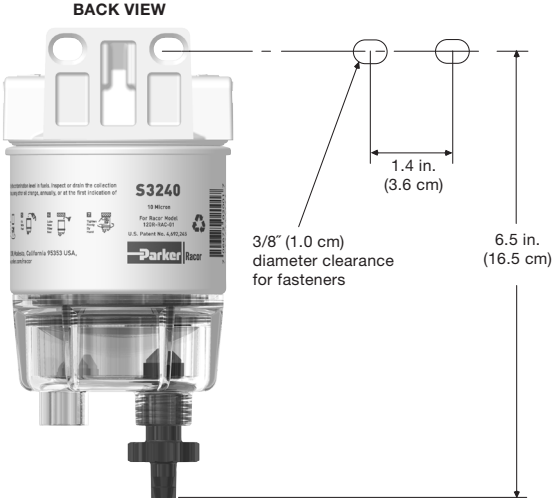
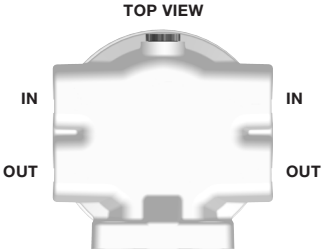

Installation Diagram

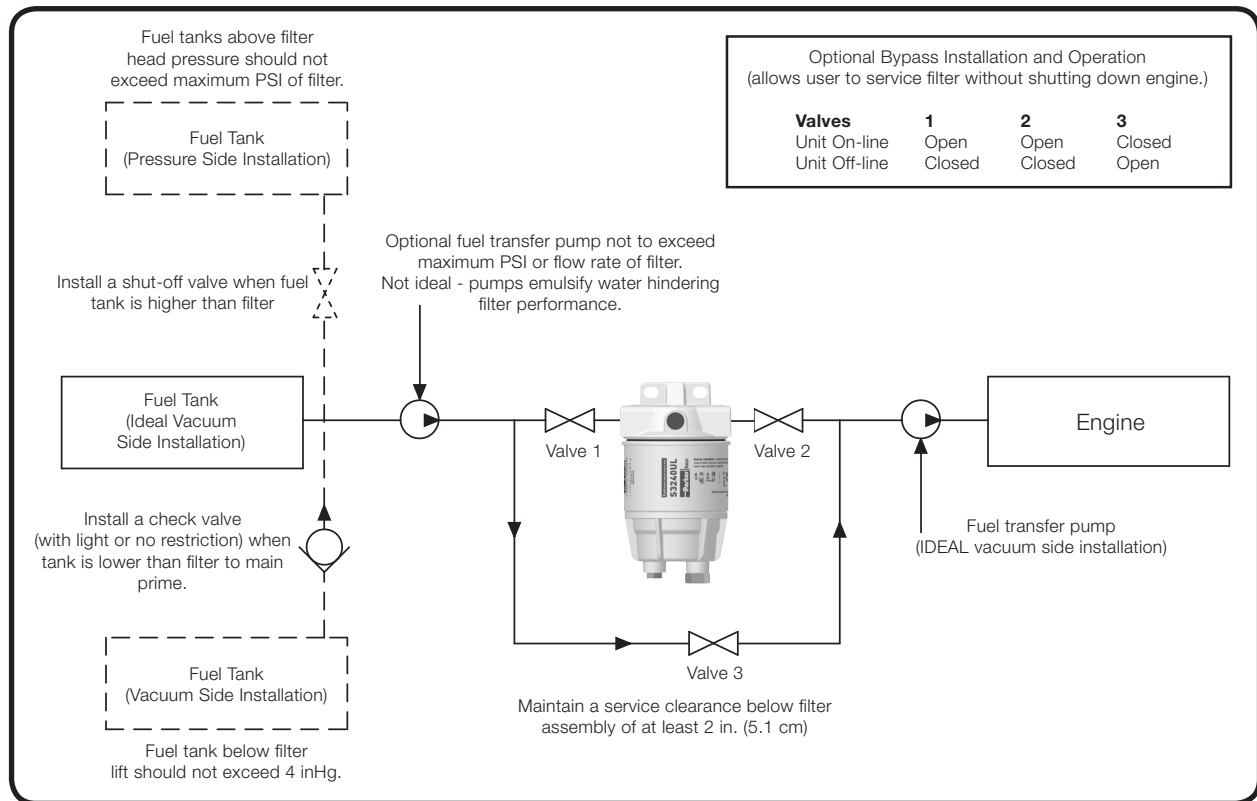

Limited Warranties Statement

All products manufactured or distributed by Racor are subject to the following, and only the following, LIMITED EXPRESS WARRANTIES, and no others: For a period of one (1) year from and after the date of purchase of a new Racor product, Racor warrants and guarantees only to the original purchaser-user that such a product shall be free from defects of materials and workmanship in the manufacturing process. The warranty period for pumps and motors is specifically limited to ninety (90) days from date of purchase. A product claimed to be defective must be returned to the place of purchase. Racor, at its sole option, shall replace the defective product with a comparable new product or repair the defective product. This express warranty shall be inapplicable to any product not properly installed and properly used by the purchaser-user or to any product damaged or impaired by external forces.

THIS IS THE EXTENT OF WARRANTIES AVAILABLE ON THIS PRODUCT. RACOR SHALL HAVE NO LIABILITY WHATSOEVER FOR CONSEQUENTIAL DAMAGES FLOWING FROM THE USE OF ANY

DEFECTIVE PRODUCT OR BY REASON OF THE FAILURE OF ANY PRODUCT. RACOR SPECIFICALLY DISAVOWS ALL OTHER WARRANTIES, EXPRESS OR IMPLIED INCLUDING, WITHOUT LIMITATION, ALL WARRANTIES OF FITNESS FOR A PARTICULAR PURPOSE (EXCEPT FOR THOSE WHICH APPLY TO PRODUCT OR PART THEREOF THAT IS USED OR BOUGHT FOR USE PRIMARILY FOR PERSONAL, FAMILY, OR HOUSEHOLD PURPOSES), WARRANTIES OF DESCRIPTION, WARRANTIES OF MERCHANTABILITY, TRADE USAGE OR WARRANTIES OR TRADE USAGE.

Warning

Failure or improper selection or improper use of the products and/or systems described herein or related items can cause death, personal injury and property damage. This document and other information from Parker Hannifin Corporation, its subsidiaries and authorized distributors provide product and/or system options for further investigation by users

having technical expertise. It is important that you analyze all aspects of your application and review the information concerning the product or system in the current product catalog. Due to the variety of operating conditions and applications for these products or systems, the user, through its own analysis and testing, is solely responsible for making the final selection of the products and systems and assuring that all performance, safety and warning requirements of the applications are met.

The products described herein, including with limitation, product features, specifications, designs, availability and pricing, are subject to change by Parker Hannifin Corporation and its subsidiaries at any time without notice.

The following statement is required pursuant to proposition 65, applicable in the State of California: 'This product may contain a chemical known to the State of California to cause cancer or reproductive toxicity.'